

# BRK 08

## CIP Controller

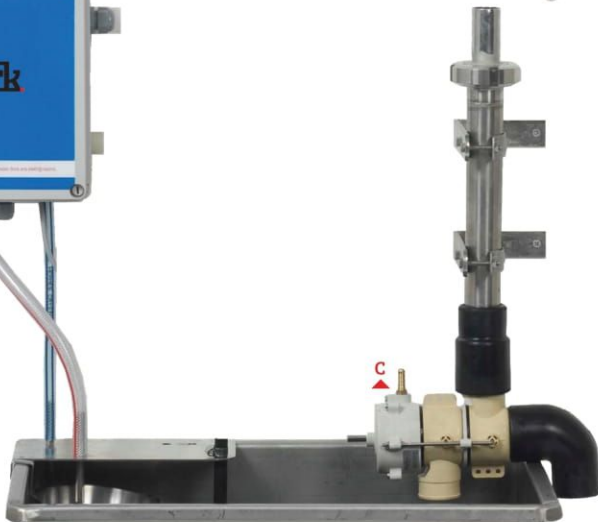

	Reference	Description
A	151420702	CIP BRK-08 Control Box
B	151420705	CIP BRK 08 Valve Box
C	150421008	CIP 3-way Drain Valve

	Reference	Description
A	150420023	CIP Selection Switch BRK-08/09
B	150420045	Start Button
C		On Off Switch
D	150450067	Power Supply 24vdc-50w
E	150450359	Fuse Box
F	150420019	CIP BRK-08 PCB

	Reference	Description
A	150420032	CIP Control Valve
B	150420010	CIP Water Inlet Valve 3/4"-10mm
C	150420010	CIP Water Inlet Valve 3/4"-10mm
D	150450263	CIP Pressure Switch
E		Vacuum Outlet From E To G
F		Vacuum Inlet
G		Vacuum Inlet From E

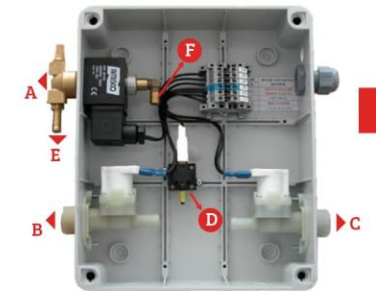
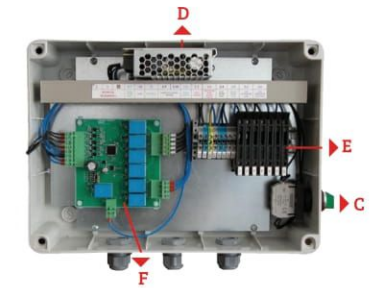

# BRK 08 CIP Controller

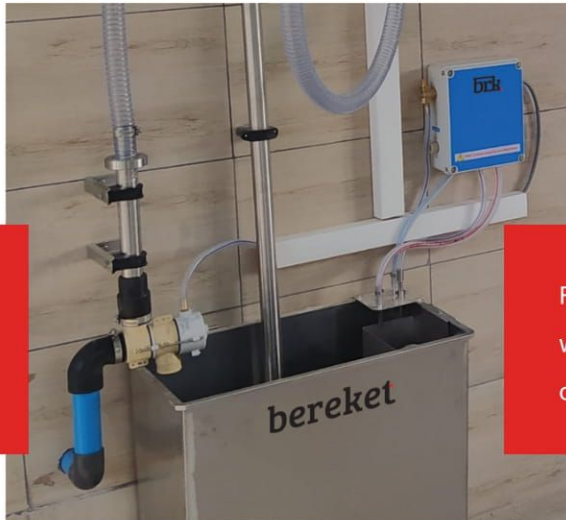
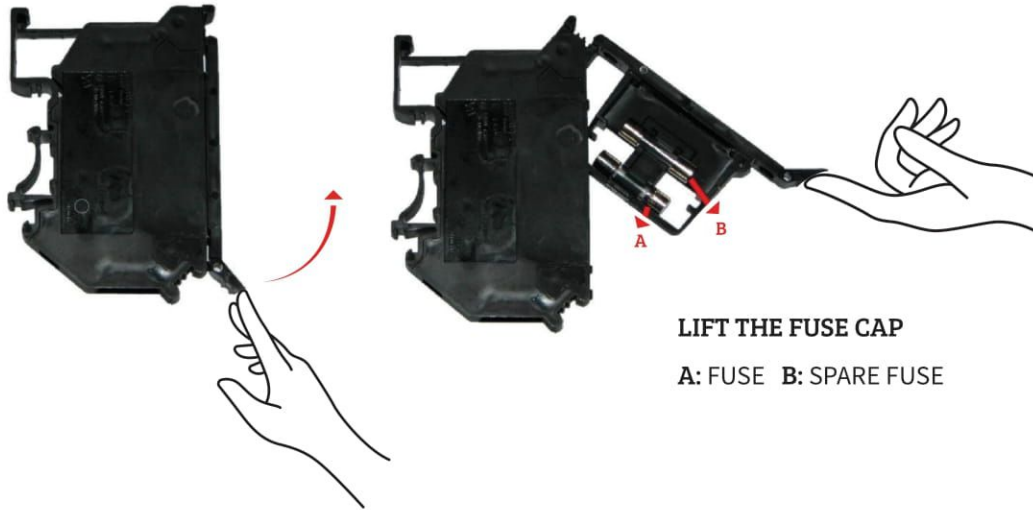

Fix the detergent can to the side of water tank so that only the hot water outlet is placed inside the can

## Program

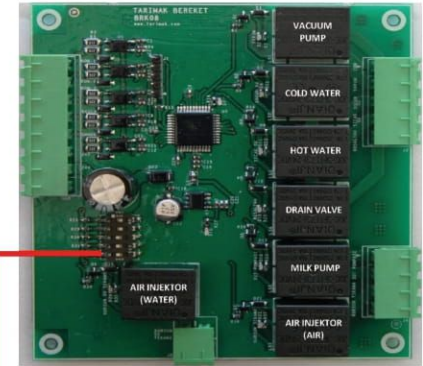

### Dipswitch

PIN	Setting	Description
PIN 1	ON	Air Injector on time 2 seconds in a one minute
	OFF	Air Injector on time 4 seconds in a one minute
PIN 2	ON	Single rinse at the end of wash cycle
	OFF	Double rinse at the end of wash cycle

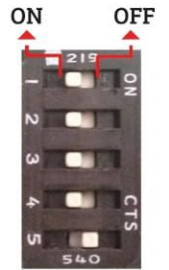

0 10 20 30 40 50 60 70 80 90 100

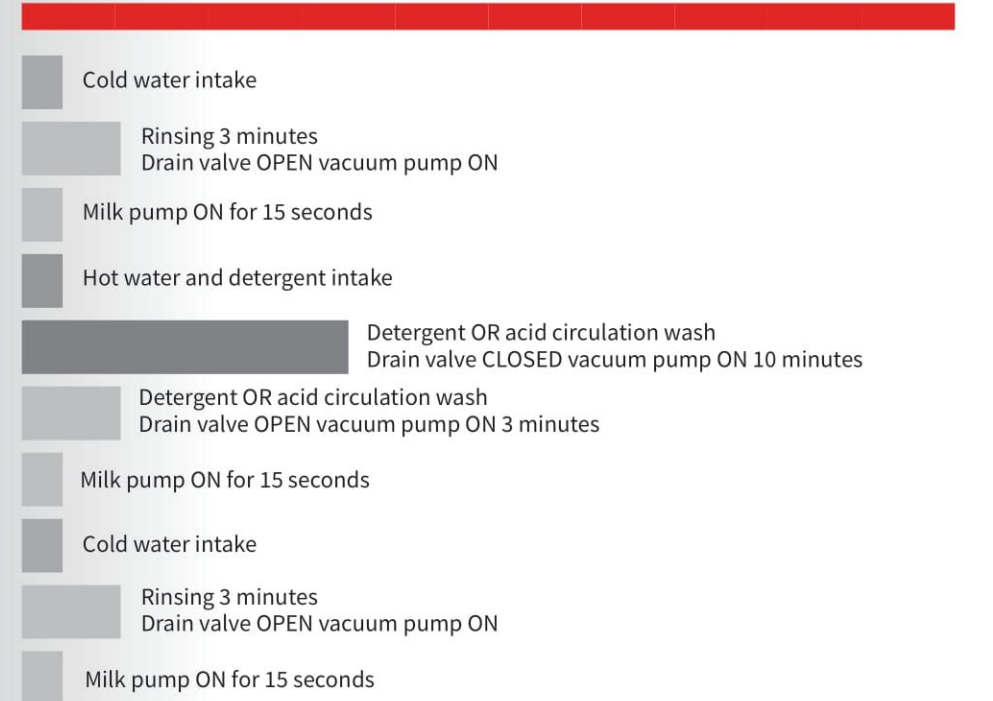

# BRK 08

## CIP Controller Wiring Diagram

**ELECTRIC BOX + BRK-08  
CONTROL BOX**

