

BRK 1500

Technical Specifications

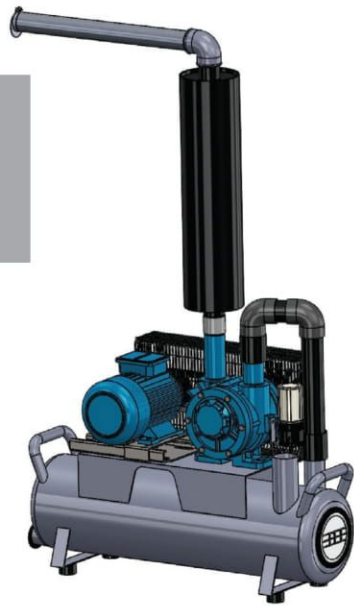

	BRK 1200	BRK 1500
Type		Rotary vane
Capacity 50 kPa	1200 l/min	1500 l/min
Vane dimensions		164X65X6 mm
Pump bearing		6305 open type
Motor	3 kw.	4 kw.
Pump pulley		17x150
Motor pulley	17x112	17x140
Pump RPM	1070	1350
Belt dimension		17x1000
Pump inlet		2"
Pump outlet		2"
Vacuum tank outlet		2 1/2"
Tank side opening		165 mm
Tank drainage		60 mm
Silencer lenght		700 mm
Silencer diameter		176 mm
Silencer pipe		2"
Oiler		Single
Oiler tube		4x8 Pvc
Oiler nipple		M6x5 mm
Pump oil nipple		M5x5 mm
Silencer drainage nipple		1/8"x8 mm
Widht		460 mm
Length		1040 mm
Height (silencer included)		1670 mm

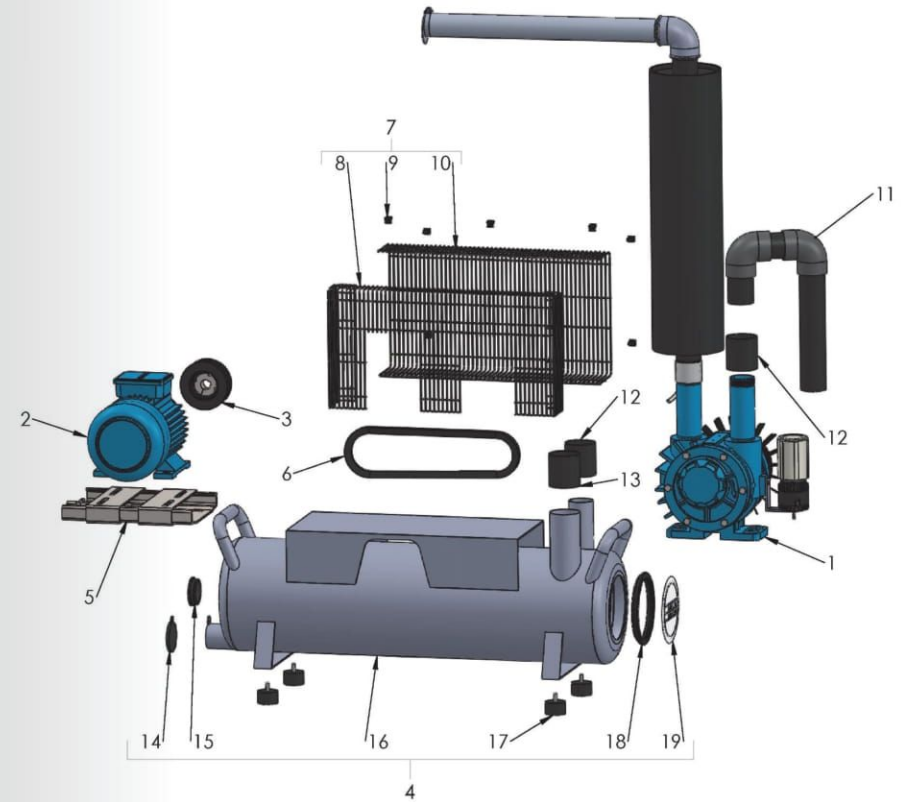

No	Reference
1	151461802
2	150461022
3	151461046
4	151461004
5	150461025
6	150461133
7	151461808
8	150461006
9	151361025
10	150361037

No	Reference
11	150461111
12	150450354
13	150461136
14	150461047
15	150411009
16	151461051
17	150361050
18	150313001
19	151313803

BRK 1500

Technical Specifications

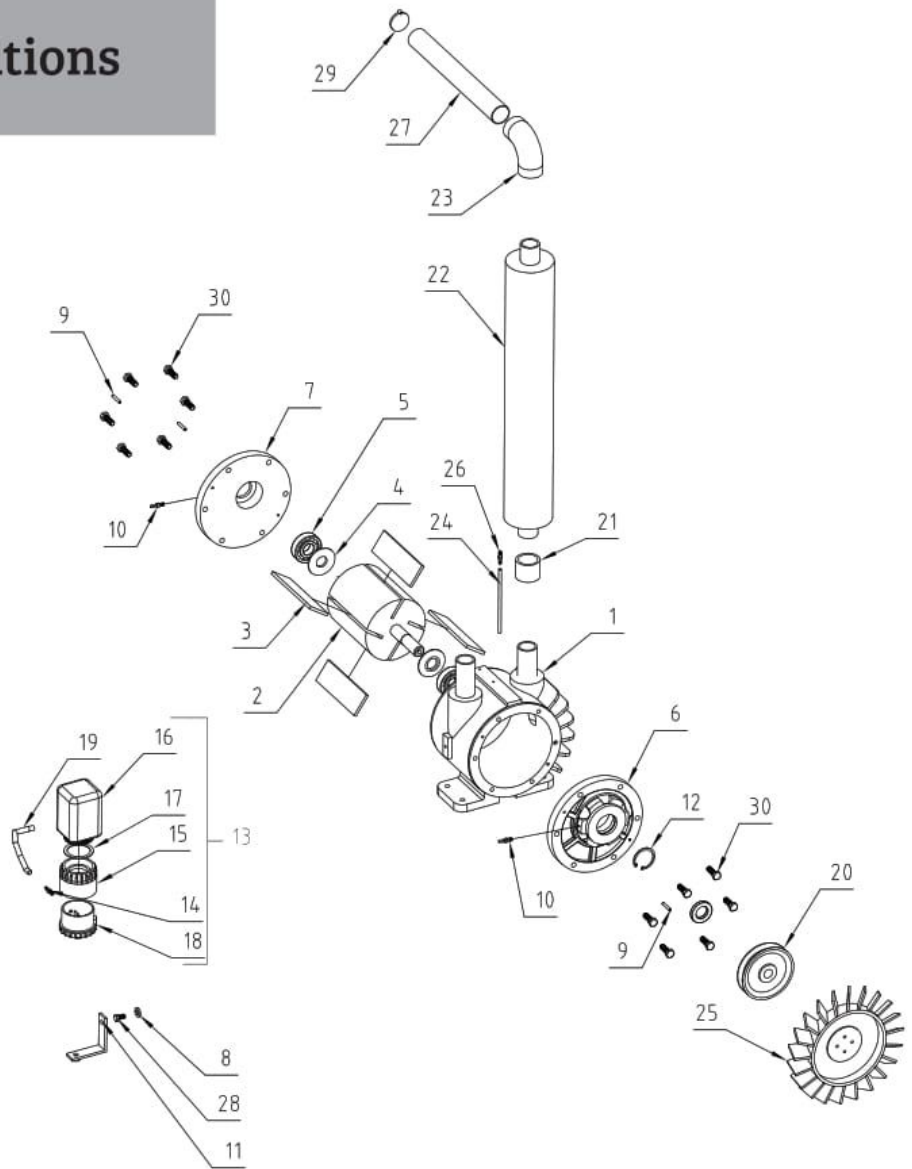

No	Reference
1	151461804
2	151461805
3	150461160
4	151461023
5	150461040
6	151461825
7	151461824
8	150350039
9	150461067
10	151461008
11	151461817
12	150361015
13	150361018
14	150361062
15	150361033
16	150361017

No	Reference
17	150361036
18	150361034
19	150361030
20	150461053
21	150461075
22	151461803
23	150461130
24	150618003

No	Reference
25	150461115
26	150461132
27	151461026
28	150361021
29	151461025
30	150461037
31	150461029