

BRK 2000

Technical Specifications

	BRK 1600	BRK 2000
Type		Rotary vane
Capacity 50 kPa	1600 l/min	2000 l/min
Vane dimensions		245X65X6 mm
Pump bearing		6305 open type
Motor	4 kw.	5,5 kw.
Pump pulley		17x150-2
Motor pulley	17x100-2	17x140-2
Pump RPM	950	1340
Belt dimension		17x1300
Pump inlet		2 1/2"
Pump outlet		2"
Silencer lenght		700 mm
Silencer diameter		176 mm
Silencer pipe		2"
Oiler		Double
Oiler tube		4x8 Pvc
Oiler nipple		M6x5 mm
Pump oil nipple		M5x5 mm
Silencer drainage nipple		1/8"x8 mm
Widht		610 mm
Length		920 mm
Height(silencer included)		1530 mm

BRK 2000

Technical Specifications

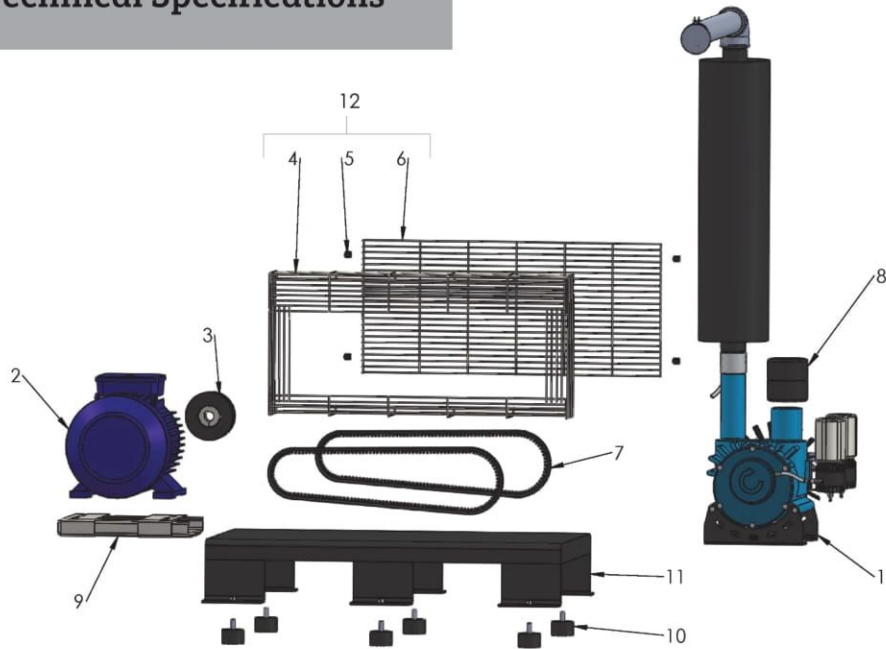

No	Reference
1	151461827
2	150461023
3	151461047
4	150461007
5	151361025
6	150461118

No	Reference
7	150461142
8	150461136
9	150461026
10	150461008
11	150461190
12	151461820

No	Reference
1	151461831
2	151461829
3	151461830
4	151461828
5	151461023
6	150461040
7	150461215
8	150461127
9	150461029
10	150461155
11	150461115
12	151461008
13	150423047
14	150461148

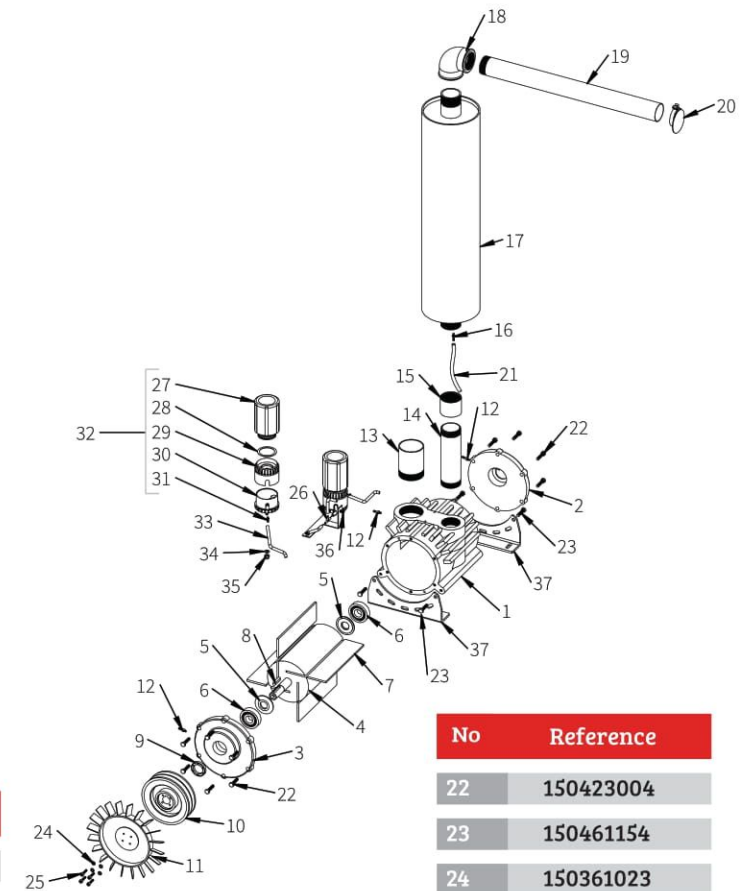

No	Reference
15	150461075
16	150461132
17	151361023
18	150461130
19	151461026
20	151461025
21	150618003

No	Reference
22	150423004
23	150461154
24	150361023
25	150311015
26	150461186
27	150361017
28	150361036
29	150361033
30	150361034
31	150361062
32	150361018
33	150361030
34	150419017
35	150461010
36	151461818
37	151461040