

BRK 350

Technical Specifications

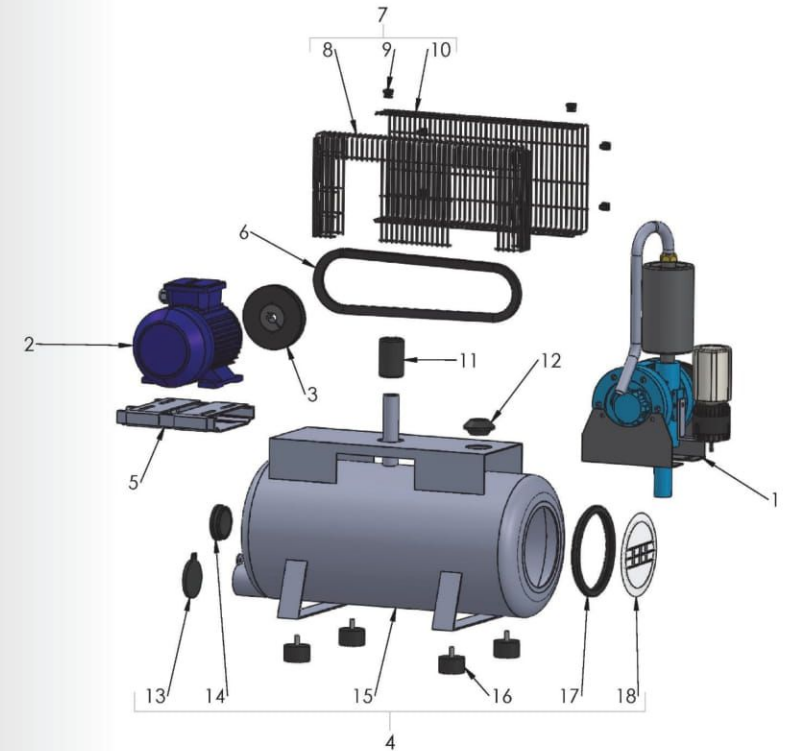
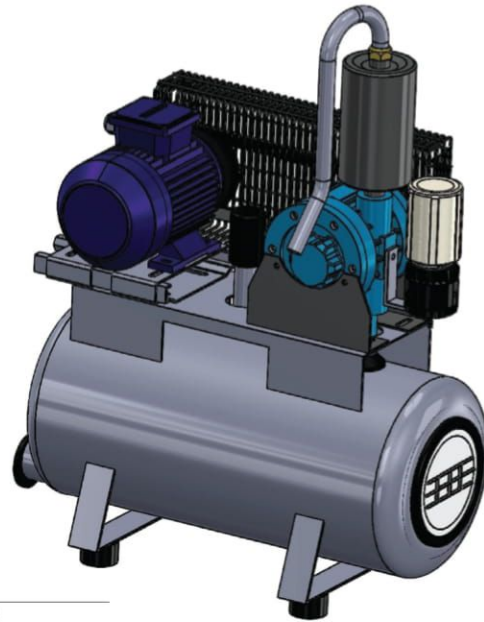

	BRK 350
Type	Rotary vane
Capacity 50 kPa	BRK 350 l /min
Vane dimensions	120x45x5 mm
Pump bearing	6204 open type
Motor	1,1 kw. Single phase
Pump pulley	13x118
Motor pulley	13x125
Pump RPM	1480
Belt dimension	13x875
Pump inlet	1 "
Pump outlet	3/4"
Vacuum tank outlet	1"
Tank side opening	165 mm
Tank drainage	60 mm
Silencer lenght	175 mm
Silencer diameter	100 mm
Silencer pipe	21 mm
Oiler	Single
Oiler tube	4x8 Pvc
Oiler nipple	M6x5 mm
Pump oil nipple	M5x5 mm
Silencer drainage nipple	M5x5 mm
Widht	340 mm
Length	650 mm
Height(silencer included)	910 mm

No	Reference
1	151361802
2	150361001
3	151361026
4	151361001
5	150361026
6	150350006
7	151361805
8	150361013
9	151361025

No	Reference
10	150361063
11	150461041
12	150361007
13	150461047
14	150411009
15	151361030
16	150361050
17	150313001
18	151313803

BRK 350

Technical Specifications

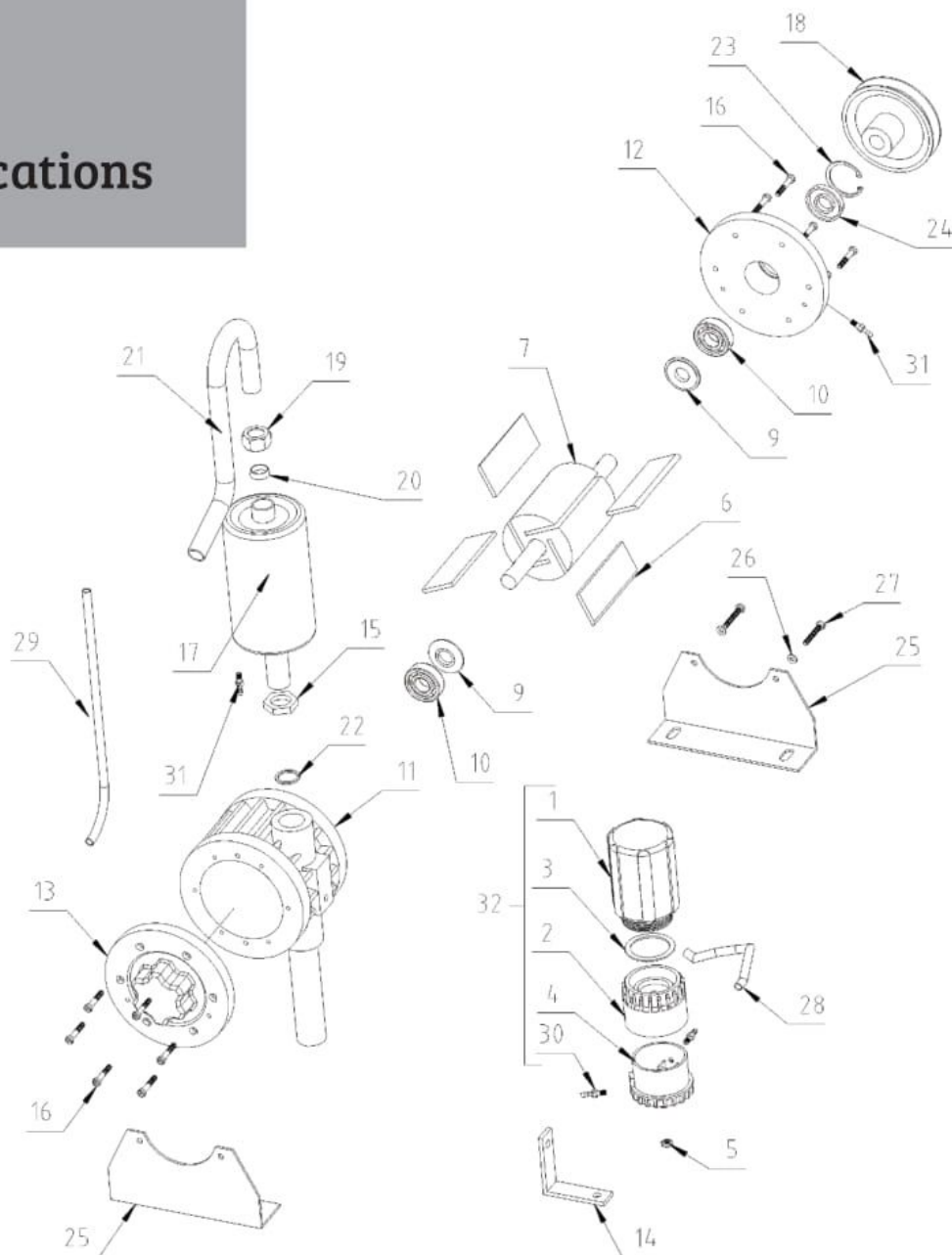

No	Reference
1	150361017
2	150361033
3	150361036
4	150361034
5	150350040
6	150361006
7	151361005
10	150361011
11	151361002
12	151361004
13	151361003
14	151461817
15	151361009
16	150311015

No	Reference
17	151361028
18	151361027
19	151361010
20	151361011
21	151361008
22	150361024
23	150361015

No	Reference
24	150361012
25	151361806
26	150361023
27	150361022
28-29	150361030
30	150361062
31	151461008
32	150361018