

BRK 750

Technical Specifications

	BRK 600	BRK 750
Type		Rotary vane
Capacity 50 kPa	600 l/min	750 l/min
Vane dimensions		82x65x6 mm
Pump bearing		6305 open type
Motor	2,2 kw. Single phase	2,2 kw. Three phase
Pump pulley		17x150
Motor pulley		17x125
Pump RPM		1160
Belt dimension		17x925
Pump inlet		1 1/4"
Pump outlet		1 1/4"
Vacuum tank outlet		1 1/2"
Tank side opening		165 mm
Tank drainage		60 mm
Silencer lenght		315 mm
Silencer diameter		103 mm
Silencer pipe		1 1/4"
Oiler		Single
Oiler tube		4x8 Pvc
Oiler nipple		M6x5 mm
Pump oil nipple		M5x5 mm
Silencer drainage nipple		M5x5 mm
Widht		400 mm
Length		920 mm
Height (silencer included)		1210 mm

BRK 750

Technical Specifications

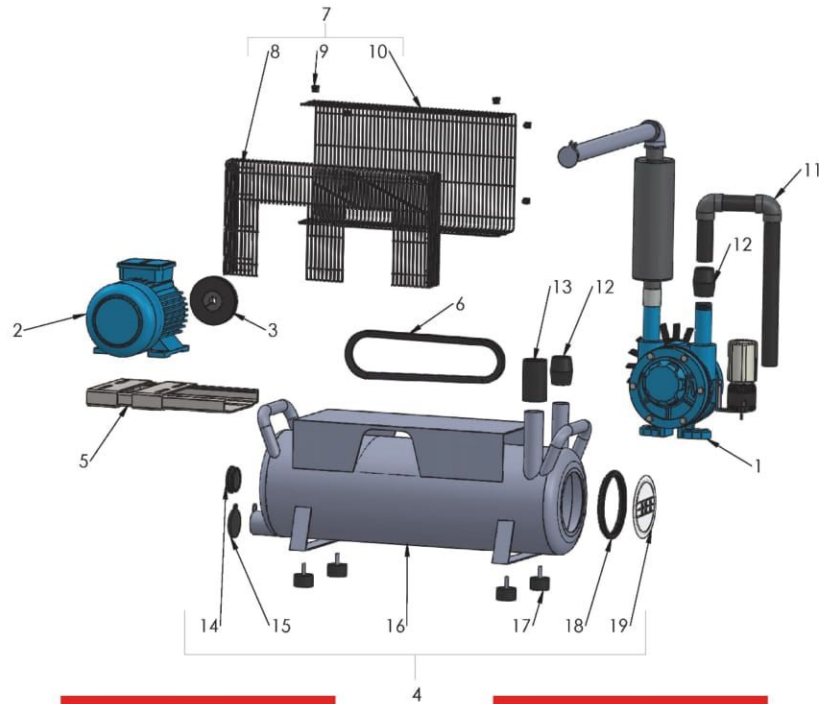

No	Reference
1	151461801
2	150461021
3	151461044
4	151461002
5	150461025
6	150461051
7	151461808
8	150461006
9	151361025
10	150361037

No	Reference
11	150461110
12	150461030
13	150450088
14	150411009
15	150461047
16	151461050
17	150461008
18	150313001
19	151313803

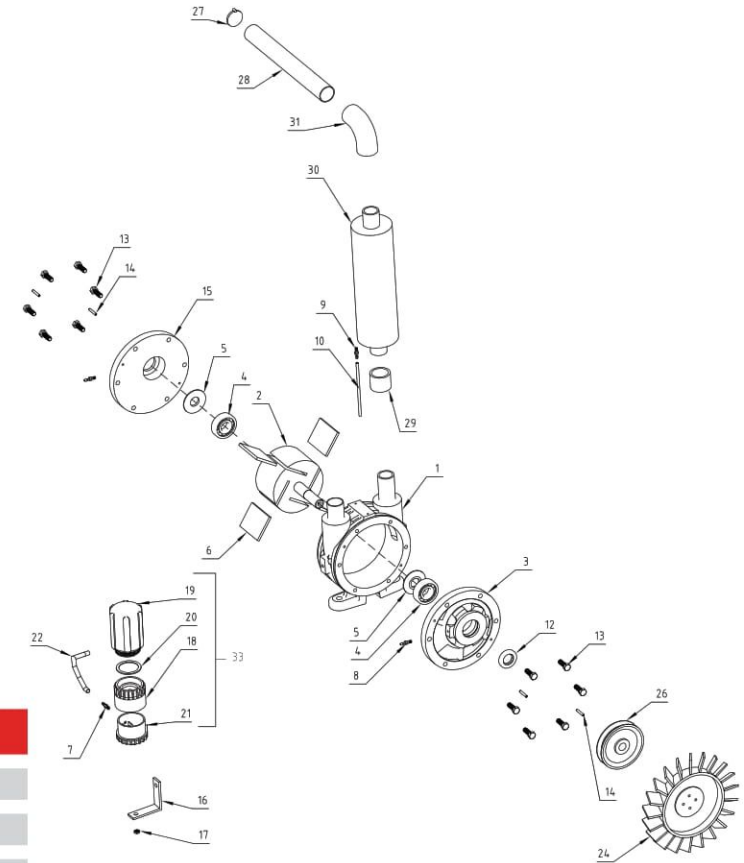

No	Reference
1	151461012
2	151461015
3	151461014
4	150461040
5	151461023
6	150461034
7	150361062
8-9	151461008
10-22	150361030
12	150461029
13	150461037
14	150461067
15	151461013
16	151461817

No	Reference
17	150350040
18	150361033
19	150361017
20	150361036
21	150361034
24	150461115
26	150461053

No	Reference
27	151461016
28	151461024
29	150461044
30	151461007
31	150461129
33	150361018